

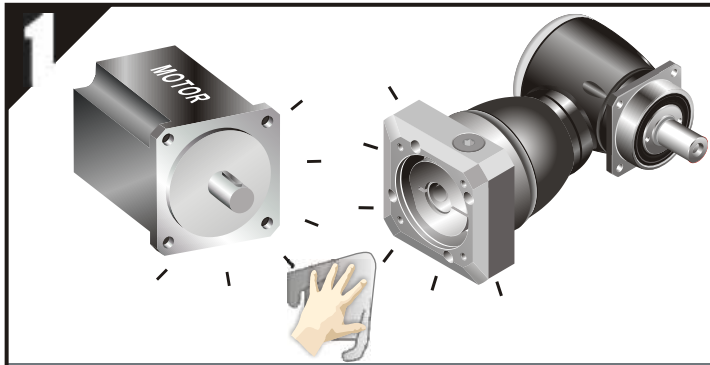

# 減速機安裝說明書 ( K 系列)

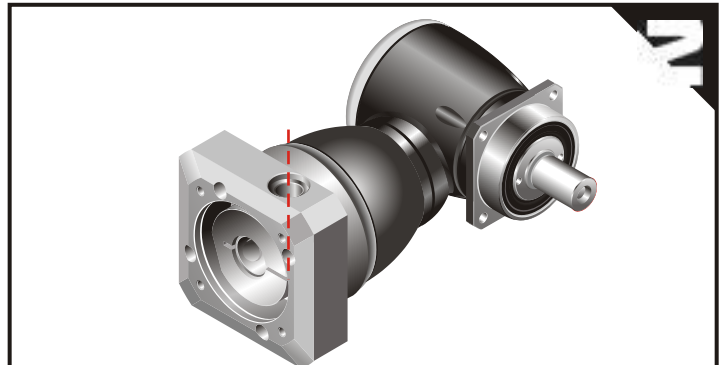

1 確認馬達與減速機規格，並將馬達及減速機之安裝面拭擦乾淨。



2 轉動馬達鎖緊殼，直到鎖緊殼螺絲對準孔蓋孔。

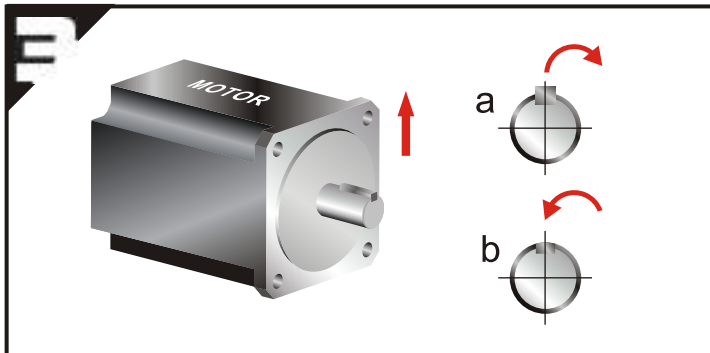

3 a. 取下馬達上原先之鍵。  
b. 如有必要，請安裝平衡鍵。

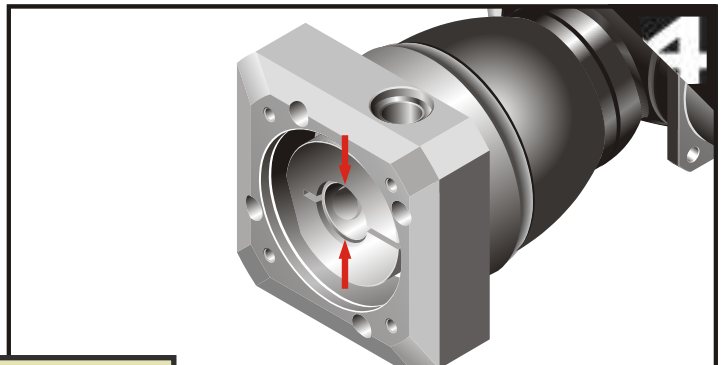

4 確認馬達軸心尺寸。  
(若有必要，裝上軸襯套)



## 正確鎖固方式

請參閱以下細部圖

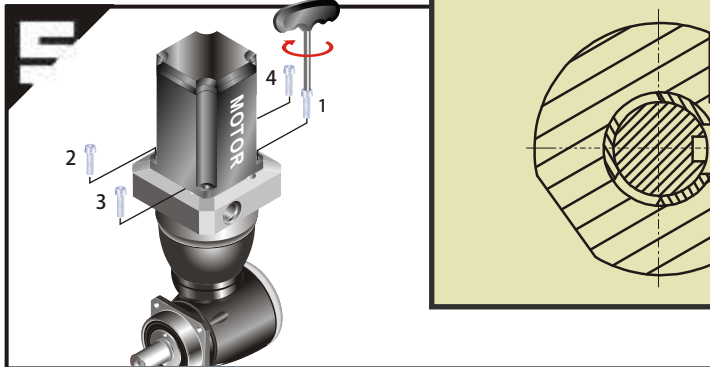
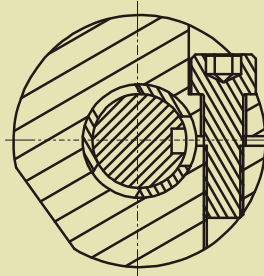

5 直立式地裝上馬達，以螺絲扭力表（表一）建議扭力值之5%，依1~4的順序，用扳手將附墊片之螺絲輕輕鎖上。

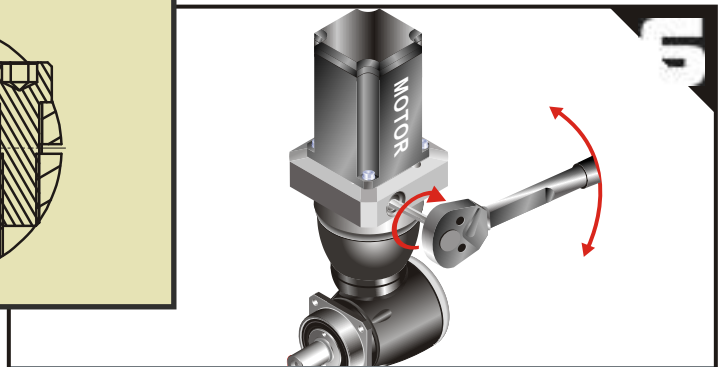

6 將馬達與減速機直立擺設，參照表二建議之扭力值，以扭力扳手將馬達鎖緊殼螺絲鎖緊。

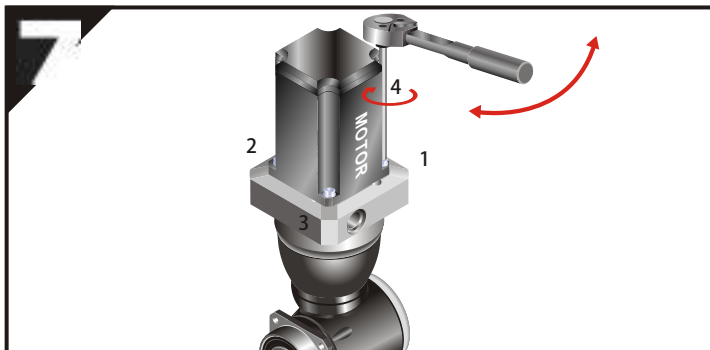

7 將馬達與減速機直立擺設，以螺絲扭力表（表一）建議之扭力值，依1~4的順序，用扭力扳手將螺絲鎖緊。

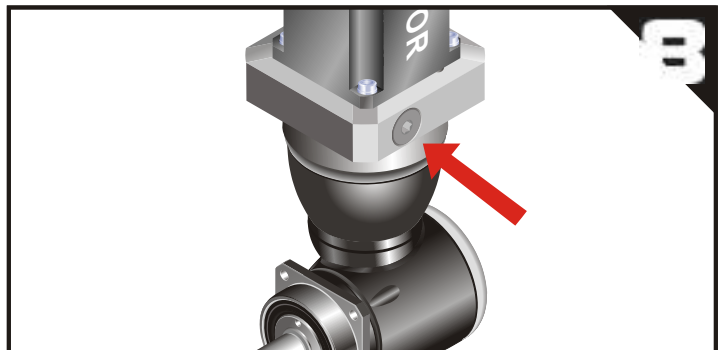

8 裝上蓋孔

**表一** 馬達鎖緊螺絲扭力建議表

| 螺絲尺寸        | 六角頭尺寸 | 強度 8.8 螺絲之鎖緊扭力 |          | 強度 10.9 螺絲之鎖緊扭力 |          | 強度 12.9 螺絲之鎖緊扭力 |          |
|-------------|-------|----------------|----------|-----------------|----------|-----------------|----------|
|             | [mm]  | [Nm]           | [In-lbs] | [Nm]            | [In-lbs] | [Nm]            | [In-lbs] |
| M3 x 0.5P   | 2.5   | 1.3            | 12       | 1.8             | 16       | 2.1             | 19       |
| M4 x 0.7P   | 3     | 3              | 27       | 4.1             | 37       | 4.9             | 44       |
| M5 x 0.8P   | 4     | 6.1            | 55       | 8.2             | 73       | 9.8             | 87       |
| M6 x 1P     | 5     | 11             | 98       | 14              | 124      | 17              | 151      |
| M8 x 1.25P  | 6     | 25             | 222      | 34              | 302      | 41              | 364      |
| M10 x 1.5P  | 8     | 49             | 434      | 67              | 594      | 80              | 709      |
| M12 x 1.75P | 10    | 85             | 753      | 116             | 1028     | 139             | 1232     |
| M14 x 2P    | 12    | 137            | 1214     | 186             | 1648     | 223             | 1976     |
| M16 x 2P    | 14    | 210            | 1860     | 286             | 2534     | 343             | 3038     |

**表二** 馬達鎖緊殼螺絲扭力建議表

| 螺絲尺寸  | [mm]     | M5 x 0.8P | M6 x 1P | M8 x 1.25P | M10 x 1.5P | M12 x 1.75P | M16 x 2P |
|-------|----------|-----------|---------|------------|------------|-------------|----------|
| 六角頭尺寸 | [mm]     | 4         | 5       | 6          | 8          | 10          | 14       |
| 鎖緊扭力  | [Nm]     | 9.8       | 17      | 41         | 80         | 139         | 343      |
|       | [In-lbs] | 87        | 151     | 364        | 709        | 1232        | 3038     |

| 機種    | KF060 |    | KF075 |    | KF100 |     | KF140 |     | KF180 |     | KF210 |     | KF240 |     |
|-------|-------|----|-------|----|-------|-----|-------|-----|-------|-----|-------|-----|-------|-----|
|       | KH064 |    | KH090 |    | KH110 |     | KH140 |     | KH200 |     | KH255 |     | KH285 |     |
| φ(C3) | 單節    | 雙節 | 單節    | 雙節 | 單節    | 雙節  | 單節    | 雙節  | 單節    | 雙節  | 單節    | 雙節  | 單節    | 雙節  |
| 8     | M5    | M5 | -     | M5 | -     | -   | -     | -   | -     | -   | -     | -   | -     | -   |
| 11    | M5    | M5 | M5    | M5 | -     | -   | -     | -   | -     | -   | -     | -   | -     | -   |
| 14    | M5    | M5 | M6    | M5 | -     | M6  | -     | -   | -     | -   | -     | -   | -     | -   |
| 19    | M6    | -  | M6    | M6 | M8    | M6  | -     | M8  | -     | -   | -     | -   | -     | -   |
| 24    | -     | -  | M10   | -  | M10   | M10 | M10   | M10 | -     | M10 | -     | -   | -     | -   |
| 28    | -     | -  | -     | -  | M10   | -   | M10   | M10 | -     | M10 | -     | -   | -     | -   |
| 32    | -     | -  | -     | -  | M10   | -   | M10   | M10 | M10   | M10 | -     | M10 | -     | -   |
| 35    | -     | -  | -     | -  | M12   | -   | M12   | M12 | M12   | M12 | M12   | M12 | M12   | M12 |
| 38    | -     | -  | -     | -  | M12   | -   | M12   | M12 | M12   | M12 | M12   | M12 | M12   | M12 |
| 42    | -     | -  | -     | -  | -     | -   | M12   | -   | M12   | M12 | M12   | M12 | M12   | M12 |
| 48    | -     | -  | -     | -  | -     | -   | M16   | -   | M16   | M16 | M16   | M16 | M16   | M16 |
| 55    | -     | -  | -     | -  | -     | -   | -     | -   | -     | -   | M16   | -   | M16   | -   |
| 60    | -     | -  | -     | -  | -     | -   | -     | -   | -     | -   | -     | -   | M16   | -   |

備註：螺絲鎖緊扭力必須大於上述值。若有需要時，可將鎖緊扭力多增加上述建議值之 20 %，以避免打滑。



**APEX DYNAMICS, INC.**

电话: 0571-86622450  
 邮箱: info@hzmosen.com

传真: 0571-86625450  
 网址: www.apexms.cn

杭州市滨江区聚源路8号创海基地D503室