

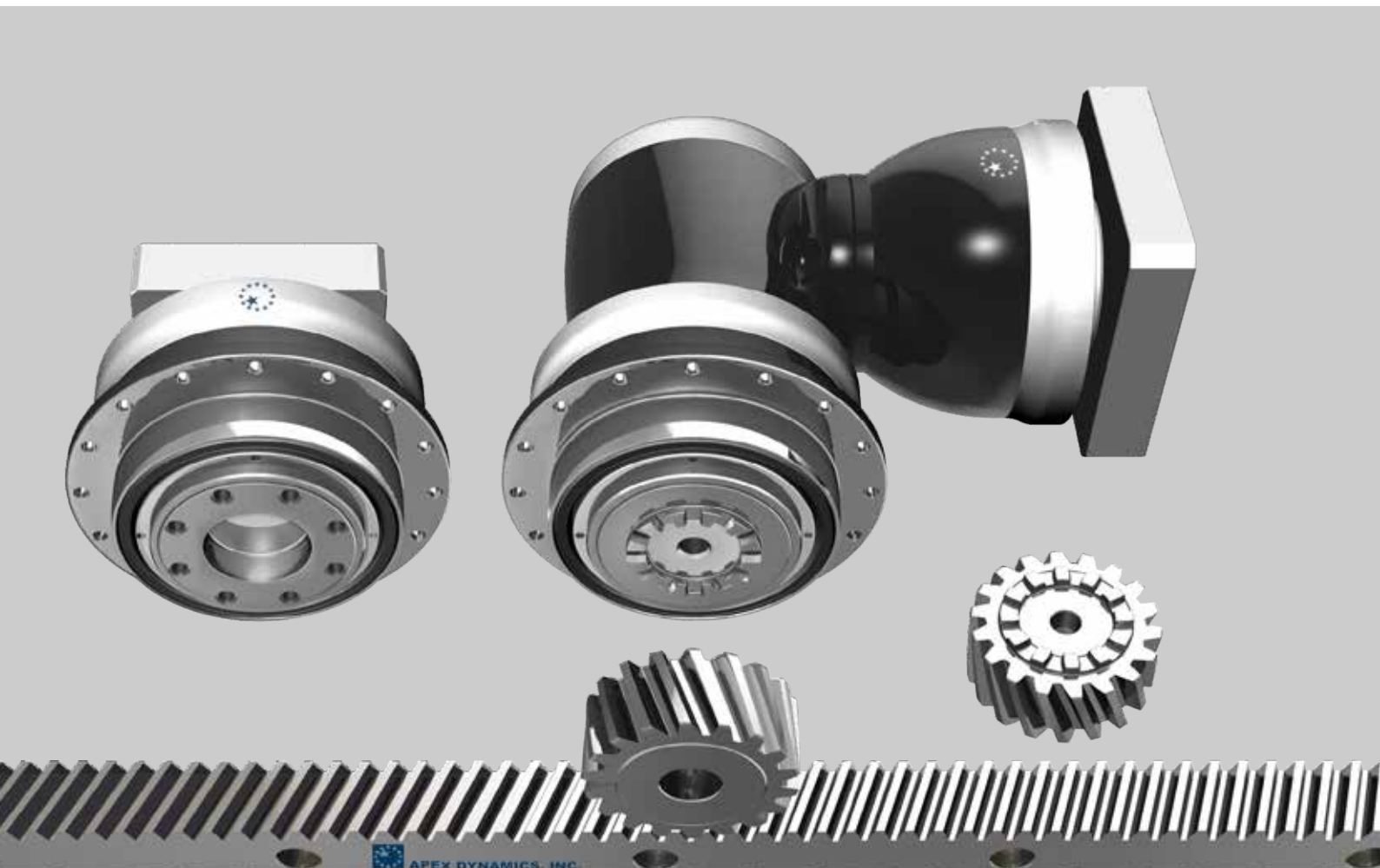

APEX DYNAMICS, INC.

**高扭力
高精度
行星式减速机
AP / APK
APC / APCK 系列**



减速机系列 -AP / APK / APC / APCK

▶ 产品特性

- 高扭力
- 最佳化扭力及惯性力矩输出
- 高精度
- 耐久高精度设计
- 低噪音
- 低温升
- 支持法兰与曲齿介面
- 特别适用于齿轮齿条应用



AP



APC



APK



APCK

减速机订购代码

API10	—	005.5⁽¹⁾	/	马达
APK110	—	005.5⁽¹⁾	/	马达
				马达类型
				比数
				减速机尺寸

减速机尺寸

AP 110 / 140 / 200 / 255 / 285 / 355 / 450
APC 110 / 140 / 200 / 255 / 285 / 355 / 450
APK 110 / 140 / 200 / 255 / 285 / 355 / 450
APCK 110 / 140 / 200 / 255 / 285 / 355 / 450

比数

AP/APC (单节) 5.5
AP/APC (双节) 22 / 27.5 / 38.5 / 55
AP/APC (三节) 88 / 110 / 154 / 220
APK/APCK (双节) 5.5 / 11 / 22 / 27.5 / 38.5 / 55
APK/APCK (三节) 88 / 110 / 137.5 / 154 / 220 / 385
APK/APCK (四节) 440 / 550 / 770 / 1078 / 1540 / 2695 / 3850 / 5500

马达类型：制造商及型号

(1) 减速比 ($i = N_{in} / N_{out}$)。



©2017 台湾精锐科技股份有限公司
 台湾精锐科技股份有限公司保留所有技术细节、插图以及工程图面的修改权利，
 本型录之产品细节将随未来发展及必要设变进行调整。
 最新产品资讯及变动，请洽询网站 <http://www.apexdyna.com/>。

性能 - AP / APC 减速机

型 号		节 数	减速比 ⁽¹⁾	AP 110 APC 110	AP 140 APC 140	AP 200 APC 200	AP 255 APC 255	AP 285 APC 285	AP 355 APC 355	AP 450 APC 450
额定输出力矩 T _{2N}	Nm	1	5.5	370	645	1,430	2,175	4,060	-	-
			22	375	650	1,445	2,200	4,100	6,995	13,810
		2	27.5	375	655	1,445	2,200	4,105	7,000	13,825
			38.5	375	655	1,450	2,200	4,110	7,010	13,845
			55	315	655	1,450	2,205	4,110	7,020	13,855
		3	88	380	655	1,450	2,205	4,115	7,025	13,865
			110	380	655	1,450	2,205	4,115	7,025	13,870
			154	380	655	1,450	2,205	4,120	7,030	13,875
			220	380	655	1,450	2,205	4,120	7,030	13,875
		急停力矩 T _{2NOT}	Nm	1,2,3	5.5~220	3倍额定输出力矩				
最大加速力矩 T _{2B}	Nm	1,2,3	5.5~220	1.5倍额定输出力矩						
空载力矩 ⁽²⁾	Nm	1	5.5	2.5	7.1	14	22	28	-	-
		2	22~55	1.1	3.7	8	12	18	17	26
		3	88~220	0.7	1.6	4	4.5	6.5	6	12
背隙 ⁽³⁾	arcmin	1,2,3	5.5~220	≤ 1						
扭转刚性	Nm/arcmin	1,2,3	5.5~220	95	205	650	1,200	1,800	2,850	5,700
额定输入转速 n _{1N}	rpm	1	5.5	3,600	3,000	2,700	2,400	2,100	-	-
		2	22~55	4,600	4,000	3,700	3,400	3,100	2,500	2,000
		3	88~220	5,000	4,600	4,000	3,700	3,400	3,100	2,500
最大输入转速 n _{1B}	rpm	1	5.5	6,000	5,000	4,500	4,000	3,500	-	-
		2	22~55	7,000	6,000	5,500	5,000	4,500	4,000	3,500
		3	88~220	7,000	7,000	6,000	5,500	5,000	4,500	4,000
容许轴向力 F _{2a} ⁽⁴⁾	N	1,2,3	5.5~220	4,070	8,530	17,000	26,900	39,200	101,500	143,700
容许侧倾力矩 M _{2k} ⁽⁴⁾	Nm	1,2,3	5.5~220	480	1,310	3,530	5,920	9,230	29,100	63,300
使用寿命 ⁽⁵⁾	hr	1,2,3	5.5~220	20,000						
使用温度	°C	1,2,3	5.5~220	-10° C~ 90° C						
防护等级		1,2,3	5.5~220	IP65						
润滑		1,2,3	5.5~220	合成润滑油脂						
安装方向		1,2,3	5.5~220	任意方向						
噪音值 ⁽²⁾	dB(A)	1	5.5	≤ 64	≤ 66	≤ 66	≤ 68	≤ 68	-	-
		2	22~55	≤ 62	≤ 64	≤ 66	≤ 67	≤ 67	≤ 68	≤ 70
		3	88~220	≤ 62	≤ 64	≤ 66	≤ 66	≤ 67	≤ 67	≤ 68
效率 η	%	1	5.5	≥ 97%						
		2	22~55	≥ 94%						
		3	88~220	≥ 92%						

(1) 减速比 (i = N_{in} / N_{out})。

(2) 以减速机减速比 5.5 (单节)、减速比 55 (双节) 及减速比 220 (三节) 转速为 3000 rpm 且无负载状态下测得数据。

(3) 背隙是在受力 2% 的额定输出力矩 T_{2N} 下测得。

(4) 输出转速 100 rpm 时, 作用于法兰 / 齿齿连结位置。计算公式请参考图片一。

(5) 不建议连续运转。

$$\text{容许侧倾力矩 } M_{2k} = \frac{F_{2a} * Y + F_{2r} * (X + Z_2)}{1000}$$

M_{2k} : [Nm]

F_{2a}, F_{2r} : [N]

X, Y, Z₂ : [mm]

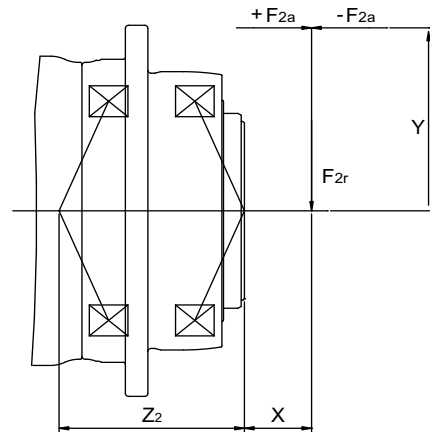

图片一

AP / APK	110	140	200	255	285	355	450
Z ₂ [mm]	106.2	90	122.8	133.2	175.5	220.6	275.3

惯量 - AP / APC 减速机

型号		AP/APC 110			AP/APC 140			AP/APC 200			AP/APC 255			AP/APC 285		
Ø ^(A)	节	1	2	3	1	2	3	1	2	3	1	2	3	1	2	3
14	kg.cm ²	-	-	0.21	-	-	-	-	-	-	-	-	-	-	-	-
19		1.68	0.68	0.63	-	-	0.68	-	-	-	-	-	-	-	-	-
24		4.89	4.52	-	6.83	5.04	4.52	-	-	5.04	-	-	-	-	-	-
28		6.18	-	-	6.69	6.33	-	-	-	6.33	-	-	7.18	-	-	-
32		8.58	-	-	9.6	8.73	-	-	10.1	8.73	-	-	10.1	-	-	-
35		13.89	-	-	15.05	14.04	-	15.79	15.54	14.04	-	17.75	15.54	-	-	17.75
38		18.91	-	-	20.82	19.05	-	21.3	21.32	19.05	-	23.26	21.32	-	27.05	23.26
42		-	-	-	22.71	-	-	23.43	23.2	-	24.84	25.4	-	-	28.95	25.4
48		-	-	-	55.58	-	-	59.06	56.07	-	60.55	61.02	-	64.93	64.66	61.02
55		-	-	-	-	-	-	-	-	-	88.2	-	-	92.99	-	-
60		-	-	-	-	-	-	-	-	-	-	-	-	115.8	-	-

型号		AP/APC 355		AP/APC 450	
Ø ^(A)	节	2	3	2	3
14	kg.cm ²	-	-	-	-
19		-	-	-	-
24		-	-	-	-
28		-	-	-	-
32		-	-	-	-
35		-	-	-	-
38		-	-	-	27.05
42		28.79	25.4	-	28.95
48		92.76	61.02	106.06	64.66
55		105.41	-	118.67	-
60		-	-	127.37	-

(A) Ø = 减速机输入端孔径。

尺寸 - AP 减速机

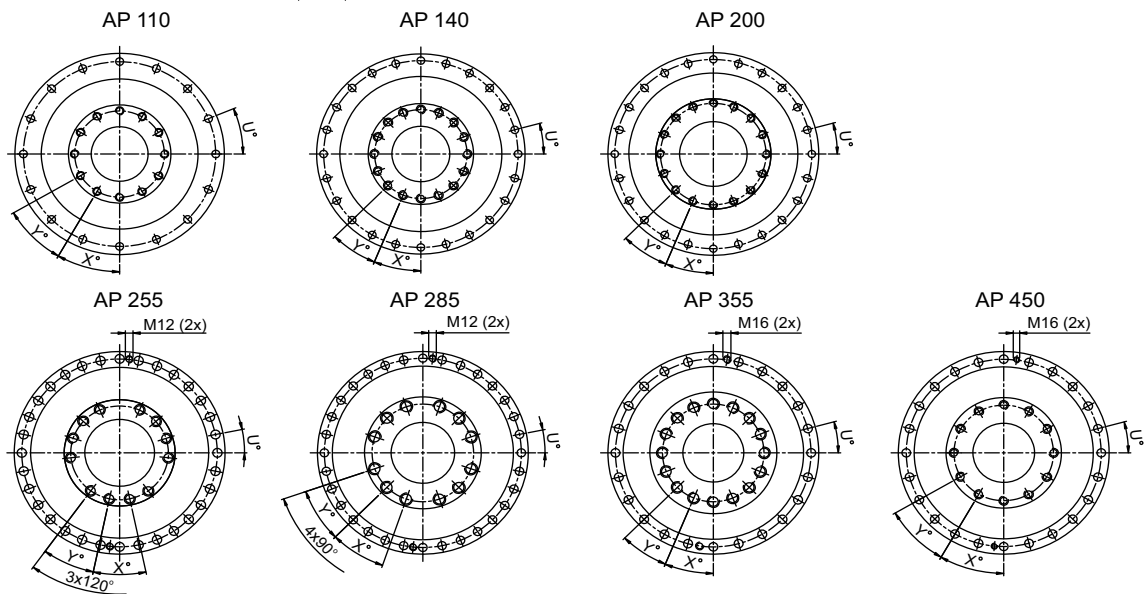
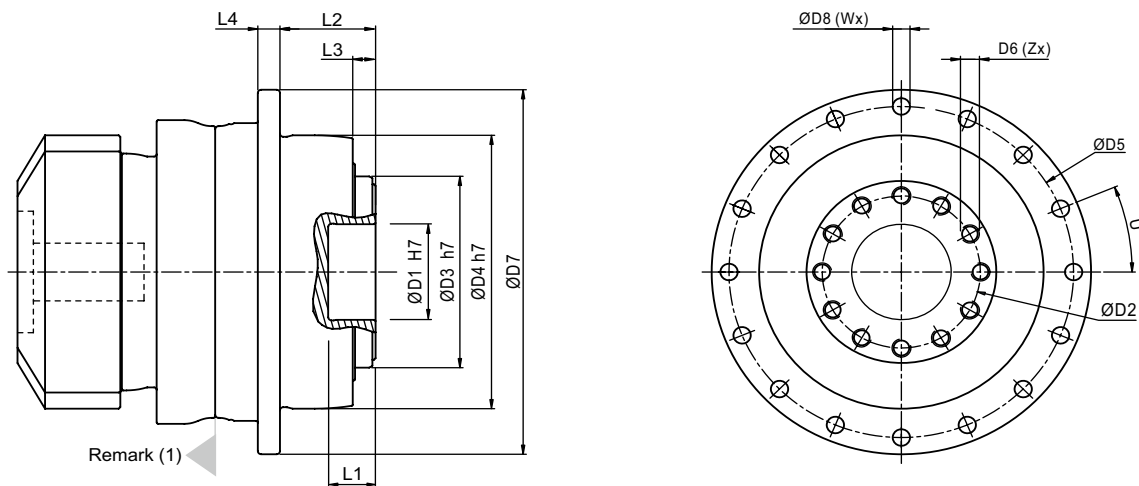

尺寸	AP 110	AP 140	AP 200	AP 255	AP 285	AP 355	AP 450
D1 H7	40	50	80	100	100	120	155
D2	63	80	125	140	160	200	250
D3 h7	80	100	160	180	200	250	315
D4 h7	110	140	200	255	285	355	450
D5	135	168	233	280	310	385	490
D6 x Pitch x Deep	M8x1.25Px12	M8x1.25Px15	M10x1.5Px20	M16x2Px25	M24x3Px37	M24x3Px32	M30x3.5Px40
D7	147	180	249.5	302	332	415	530
D8	5.5	6.6	9	13.5	13.5	17.5	22
L1	15	15	16	16	16	35	24
L2	29	38	50	66	75	80	85
L3	7	7.5	8.5	13.5	16.5	20	20
L4	8	10	12	18	20	45	60
X in Degree	30	22.5	22.5	24	26	22.5	30
Y in Degree	30	22.5	22.5	24	26	22.5	30
Z	12	16	16	12	12	16	12
U in Degree	22.5	15	15	11.25	11.25	15	15
W	16	24	24	32	32	24	24

(1) 尺寸与马达介面有关，详细资料请与 APEX 洽询。

尺寸 - AP 减速机

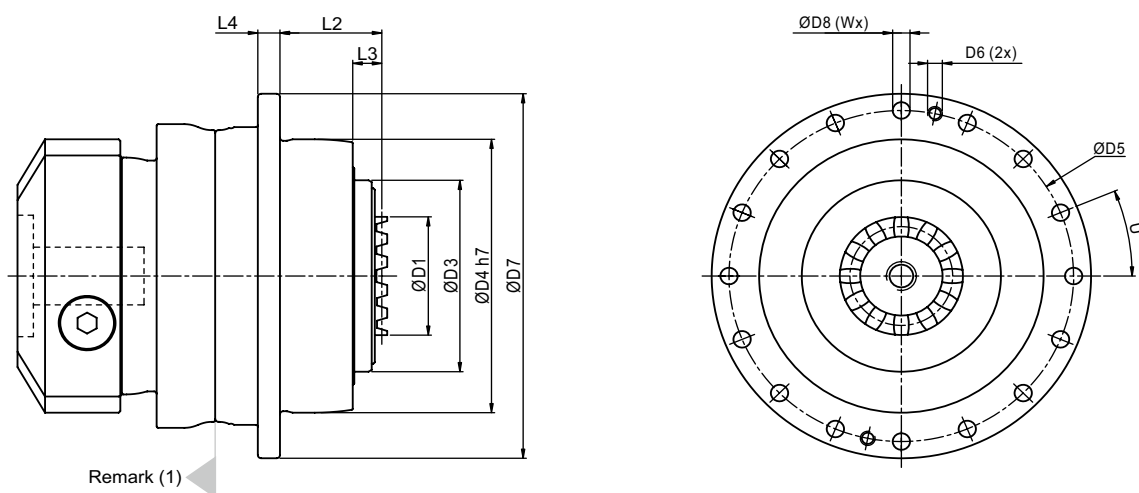

尺寸	APC 110	APC 140	APC 200	APC 255	APC 285	APC 355	APC 450
D1	46	60	80	90	120	120	132
D3	80	100	160	180	200	250	315
D4 h7	110	140	200	255	285	355	450
D5	135	168	233	280	310	385	490
D6	-	-	-	M12	M12	M16	M16
D7	147	180	249.5	302	332	415	530
D8	5.5	6.6	9	13.5	13.5	17.5	22
L2	31.5	40.5	52.5	68.5	77.5	82.5	87.5
L3	9.5	10	11	16	19	22.5	22.5
L4	8	10	12	18	20	45	60
U in Degree	22.5	15	15	11.25	11.25	15	15
W	16	24	24	32	32	24	24

(1) 尺寸与马达介面有关，详细资料请与 APEX 洽询。

性能 - APK / APCK 减速机

型 号	节 数	减 速 比 ⁽¹⁾	APK 110 APCK 110	APK 140 APCK 140	APK 200 APCK 200	APK 255 APCK 255	APK 285 APCK 285	APK 355 APCK 355	APK 450 APCK 450	
额定输出力矩 T_{2N}	2	22	375	655	1,445	2,200	4,110	7,010	-	
		27.5	375	655	1,445	2,200	4,110	7,015	-	
		38.5	375	655	1,450	2,200	4,110	7,020	-	
		55	315	655	1,450	2,205	4,115	7,025	-	
	3	88	380	655	1,450	2,205	4,115	7,025	13,870	
		110	380	655	1,450	2,205	4,115	7,025	13,870	
		137.5	380	655	1,450	2,205	4,120	7,030	13,875	
		154	380	655	1,450	2,205	4,120	7,030	13,875	
	4	220	380	655	1,450	2,205	4,120	7,030	13,200	
		385	380	655	1,450	2,205	4,120	7,030	13,880	
		440	380	655	1,450	2,205	4,120	7,030	13,880	
		550	380	655	1,450	2,210	4,120	7,030	13,880	
		770	380	655	1,450	2,210	4,120	7,030	13,880	
		1,078	380	655	1,450	2,210	4,120	7,035	13,880	
		1,540	380	655	1,450	2,210	4,120	7,035	13,885	
		2,695	380	655	1,450	2,210	4,120	7,035	13,885	
3,850	380	655	1,450	2,210	4,120	7,035	13,885			
5,500	315	655	1,450	2,210	4,120	7,035	14,010			
急停力矩 T_{2NOT}	Nm	2,3,4	2倍额定输出力矩							
最大加速力矩 T_{2B}	Nm	2,3,4	1.5倍额定输出力矩							
空载力矩 ⁽²⁾	Nm	2	22~55	2	3.1	6	13	16	20	-
		3	88~385	1.4	2.4	4.6	7	8.5	10.5	13
		4	440~5,500	0.2	0.3	0.6	0.9	1.2	1.8	2.5
背隙 ⁽³⁾	arcmin	2,3,4	≤ 1.2							
扭转刚性	Nm/arcmin	2	22~55	56	112	389	642	1,275	2,500	-
		3	88~385	56	112	389	642	1,275	2,500	5,100
		4	440~5,500	45	85	310	535	1,050	1,700	2,700
额定输入转速 n_{1N}	rpm	2	22~55	2,800	2,700	2,200	2,100	2,000	1,600	-
		3	88~385	3,000	2,800	2,700	2,200	2,100	2,100	2,000
		4	440~5,500	5,500	4,600	4,600	4,000	3,700	3,700	3,400
最大输入转速 n_{1B}	rpm	2	22~55	6,000	4,500	4,500	4,000	3,000	2,500	-
		3	88~385	6,000	6,000	4,500	4,500	4,000	4,000	3,000
		4	440~5,500	7,000	7,000	7,000	6,000	5,500	5,500	5,000
容许轴向力 F_{2a} ⁽⁴⁾	N	2,3,4	22~5,500	4,070	8,530	17,000	26,900	39,200	101,500	143,700
容许侧倾力矩 M_{2k} ⁽⁴⁾	Nm	2,3,4	22~5,500	480	1,310	3,530	5,920	9,230	29,100	63,300
使用寿命 ⁽⁵⁾	hr	2,3,4	20,000							
使用温度	°C	2,3,4	-10°C ~ 90°C							
防护等级		2,3,4	IP65							
润滑		2,3,4	合成润滑油脂							
安装方向		2,3,4	任意方向							
噪音值 ⁽²⁾	dB(A)	2,3,4	22~5,500	≤ 68	≤ 68	≤ 70	≤ 70	≤ 72	≤ 74	≤ 76
效率 η	%	2	22~5,500	≥ 94%						
		3	88~385	≥ 92%						
		4	440~5,500	≥ 90%						

(1) 减速比 ($i = N_{in} / N_{out}$)。

(2) 以减速机减速比 55 (双节), 减速比 385 (三节) 及减速比 5,500 (四节) 转速为 3000 rpm 且无负载状态下测得数据。

(3) 背隙是在受力 2% 的额定输出力矩 T_{2N} 下测得。

(4) 输出转速 100 rpm 时, 作用于法兰 / 曲齿连结位置。计算公式请参考 AP 系列页面(3)。

(5) 不建议连续运转。

惯量 - APK / APCK 减速机

型号 Ø ^(A)	号 节	APK/APCK 110			APK/APCK 140			APK/APCK 200			APK/APCK 255			APK/APCK 285			APK/APCK 355			APK/APCK 450		
		2	3	4	2	3	4	2	3	4	2	3	4	2	3	4	2	3	4	3	4	
8	kg.cm ²	-	-	0.17	-	-	-	-	-	-	-	-	-	-	-	-	-	-	-	-	-	
11		-	-	0.17	-	-	-	-	-	-	-	-	-	-	-	-	-	-	-	-	-	-
14		-	0.47	-	-	-	0.53	-	-	-	-	-	-	-	-	-	-	-	-	-	-	-
19		1.64	0.63	-	-	1.64	0.68	-	-	1.83	-	-	-	-	-	-	-	-	-	-	-	-
24		4.74	-	-	5.05	4.74	4.52	-	5.05	5.04	-	-	5.63	-	-	-	-	-	-	-	-	-
28		-	-	-	6.55	5.96	-	-	6.55	-	-	6.98	7.18	-	-	-	-	-	-	-	-	-
32		-	-	-	9.47	-	-	10.18	9.47	-	-	10.18	10.1	-	-	-	-	-	-	-	-	-
35		-	-	-	14.91	-	-	15.21	14.91	-	15.21	15.21	15.54	-	15.21	15.54	-	-	15.54	-	17.75	-
38		-	-	-	20.69	-	-	20.7	20.69	-	20.7	20.7	21.32	21.69	20.7	21.32	-	20.7	21.32	21.69	23.26	-
42		-	-	-	-	-	-	22.83	-	-	22.83	-	-	23.59	22.83	23.2	25.28	22.83	23.2	23.59	25.4	-
48		-	-	-	-	-	-	58.45	-	-	58.45	-	-	59.3	58.45	56.07	61.61	58.45	56.07	59.3	61.02	-
55		-	-	-	-	-	-	-	-	-	-	-	-	-	-	-	89.67	-	-	-	-	-

(A) Ø = 减速机输入端孔径。

尺寸 - APK (双节) 减速机 (减速比 $i = 22 \sim 55$)

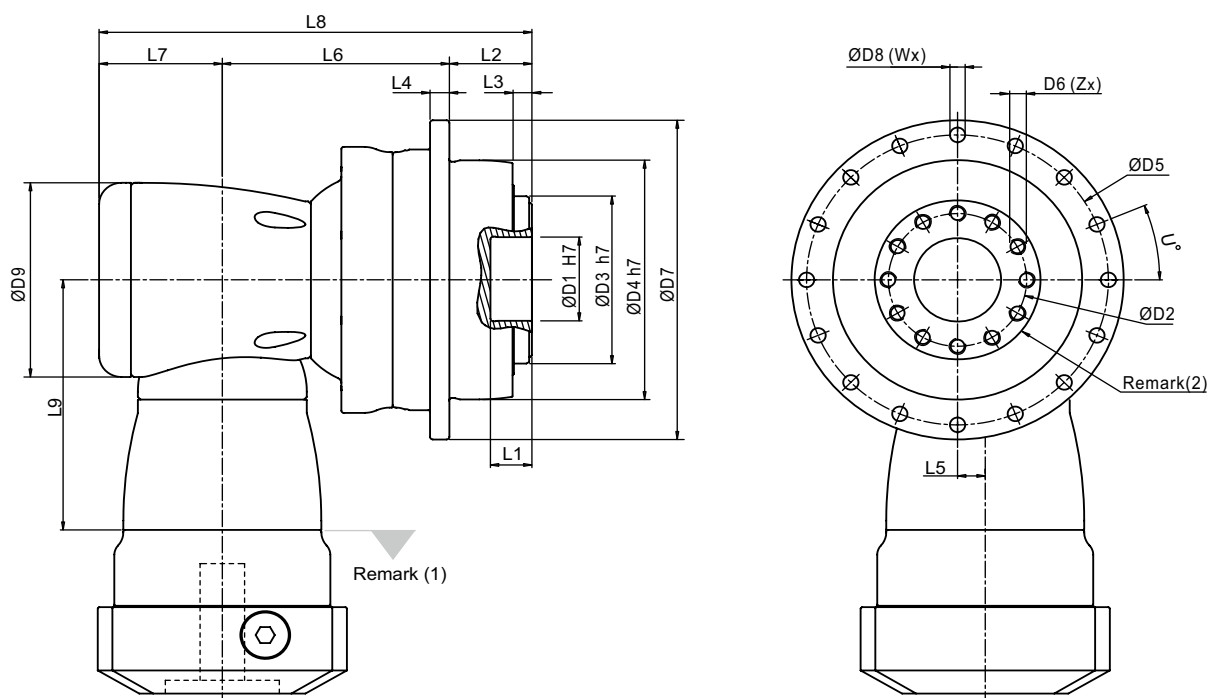

尺寸	APK 110	APK 140	APK 200	APK 255	APK 285	APK 355
D1 H7	40	50	80	100	100	120
D2	63	80	125	140	160	200
D3 h7	80	100	160	180	200	250
D4 h7	110	140	200	255	285	355
D5	135	168	233	280	310	385
D6 x Pitch x Deep	M8x1.25Px12	M8x1.25Px15	M10x1.5Px20	M16x2Px25	M24x3Px37	M24x3Px32
D7	147	180	249.5	302	332	415
D8	5.5	6.6	9	13.5	13.5	17.5
D9	116	163	210	210	255	300
L1	15	15	16	16	16	35
L2	29	38	50	66	75	80
L3	7	7.5	8.5	13.5	16.5	20
L4	8	10	12	18	20	45
L5	17	25	31	31	36	43
L6	114	147.5	175	191.5	249.5	290
L7	68.3	89	115	115	131	165
L8	211.3	274.5	340	372.5	455.5	535
L9	129	173.5	228	228	265.5	294.5
X in Degree	30	22.5	22.5	24	26	22.5
Y in Degree	30	22.5	22.5	24	26	22.5
Z	12	16	16	12	12	16
U in Degree	22.5	15	15	11.25	11.25	15
W	16	24	24	32	32	24

(1) 尺寸与马达介面有关，详细资料请与 APEX 洽询。

(2) 法兰介面请参考 AP 系列页面 (5)。

尺寸 - APK (三节) 减速机 (减速比 $i = 88 \sim 385$)

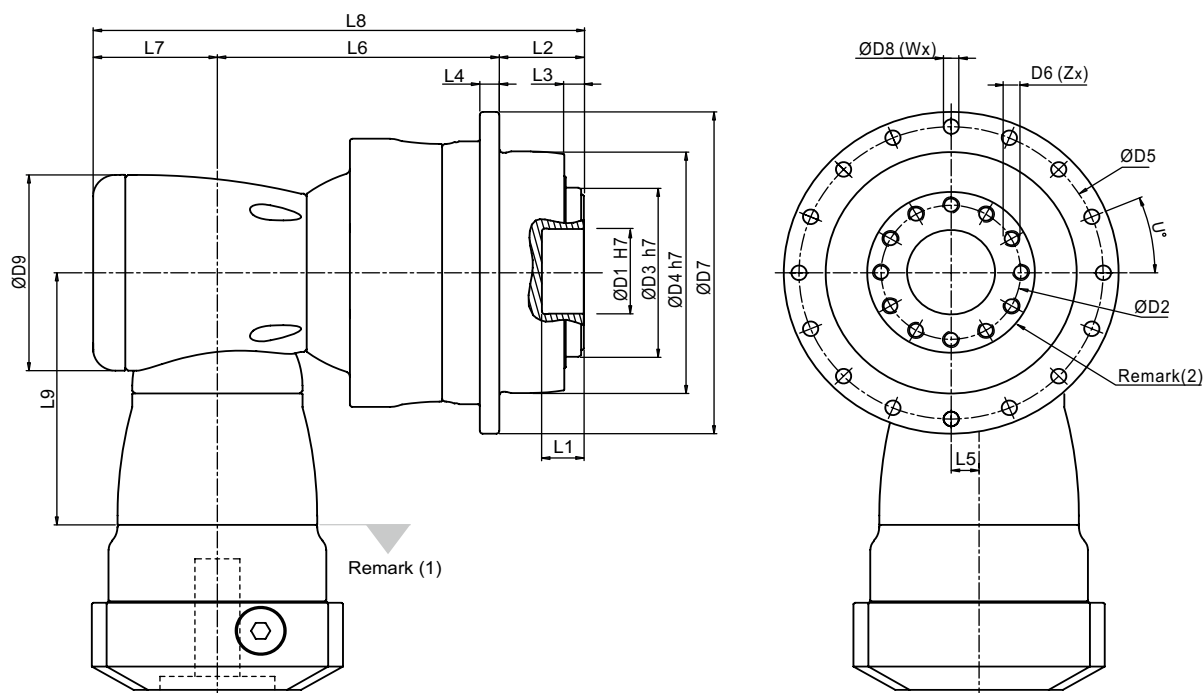

尺寸	APK 110	APK 140	APK 200	APK 255	APK 285	APK 355	APK 450
D1 H7	40	50	80	100	100	120	155
D2	63	80	125	140	160	200	250
D3 h7	80	100	160	180	200	250	315
D4 h7	110	140	200	255	285	355	450
D5	135	168	233	280	310	385	490
D6 x Pitch x Deep	M8x1.25Px12	M8x1.25Px15	M10x1.5Px20	M16x2Px25	M24x3Px37	M24x3Px32	M30x3.5Px40
D7	147	180	249.5	302	332	415	530
D8	5.5	6.6	9	13.5	13.5	17.5	22
D9	94	116	163	210	210	210	255
L1	15	15	16	16	16	35	24
L2	29	38	50	66	75	80	85
L3	7	7.5	8.5	13.5	16.5	20	20
L4	8	10	12	18	20	45	60
L5	13	17	25	31	31	31	36
L6	132	164	216.5	254.5	300	332	447.5
L7	53	68.3	89	115	115	115	131
L8	214	270.3	355.5	435.5	490	527	663.5
L9	114.5	129	173.5	228	228	228	265.5
X in Degree	30	22.5	22.5	24	26	22.5	30
Y in Degree	30	22.5	22.5	24	26	22.5	30
Z	12	16	16	12	12	16	12
U in Degree	22.5	15	15	11.25	11.25	15	15
W	16	24	24	32	32	24	24

(1) 尺寸与马达介面有关，详细资料请与 APEX 洽询。

(2) 法兰介面请参考 AP 系列页面 (5)。

尺寸 - APK (四节) 减速机 减速比 $i = 440 \sim 5,500$)

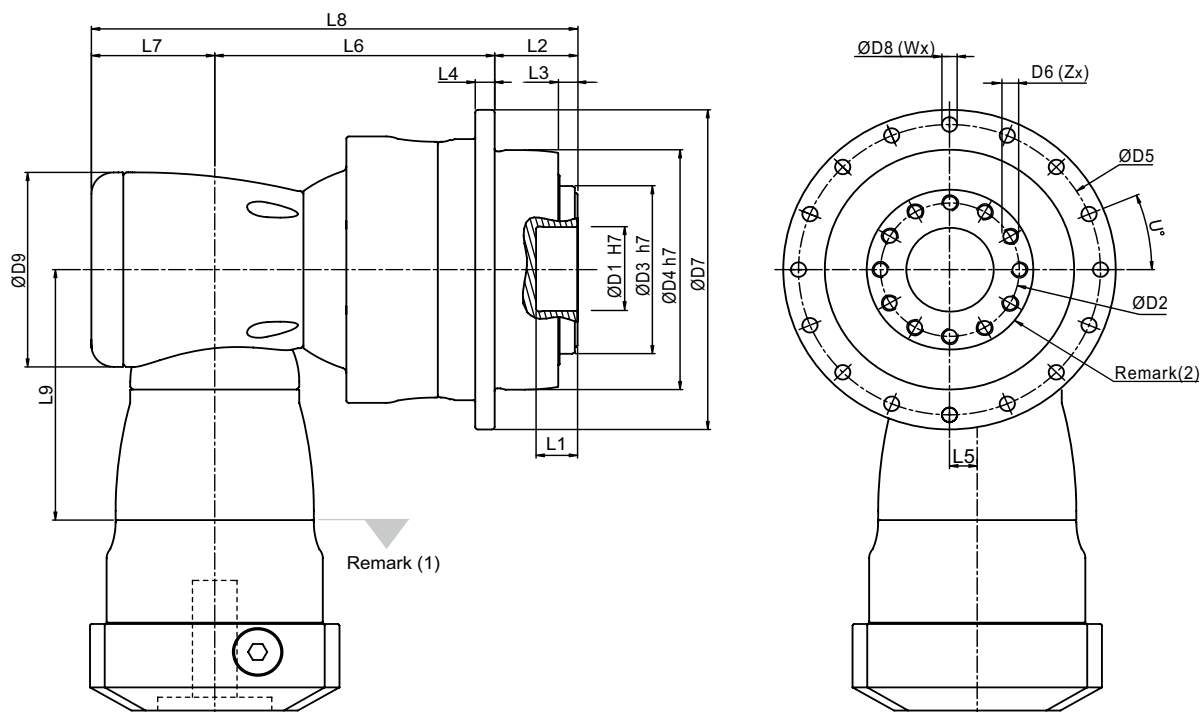

尺寸	APK 110	APK 140	APK 200	APK 255	APK 285	APK 355	APK 450
D1 H7	40	50	80	100	100	120	155
D2	63	80	125	140	160	200	250
D3 h7	80	100	160	180	200	250	315
D4 h7	110	140	200	255	285	355	450
D5	135	168	233	280	310	385	490
D6 x Pitch x Deep	M8x1.25Px12	M8x1.25Px15	M10x1.5Px20	M16x2Px25	M24x3Px37	M24x3Px32	M30x3.5Px40
D7	147	180	249.5	302	332	415	530
D8	5.5	6.6	9	13.5	13.5	17.5	22
D9	94	116	163	210	210	210	255
L1	15	15	16	16	16	35	24
L2	29	38	50	66	75	80	85
L3	7	7.5	8.5	13.5	16.5	20	20
L4	8	10	12	18	20	45	60
L5	13	17	25	31	31	31	36
L6	132	164	216.5	254.5	300	332	447.5
L7	53	68.3	89	115	115	115	131
L8	214	270.3	355.5	435.5	490	527	663.5
L9	114.5	129	173.5	228	228	228	265.5
X in Degree	30	22.5	22.5	24	26	22.5	30
Y in Degree	30	22.5	22.5	24	26	22.5	30
Z	12	16	16	12	12	16	12
U in Degree	22.5	15	15	11.25	11.25	15	15
W	16	24	24	32	32	24	24

(1) 尺寸与马达介面有关，详细资料请与 APEX 洽询。

(2) 法兰介面请参考 AP 系列页面 (5)。

尺寸 - APCK (双节) 减速机 (减速比 $i = 22 \sim 55$)

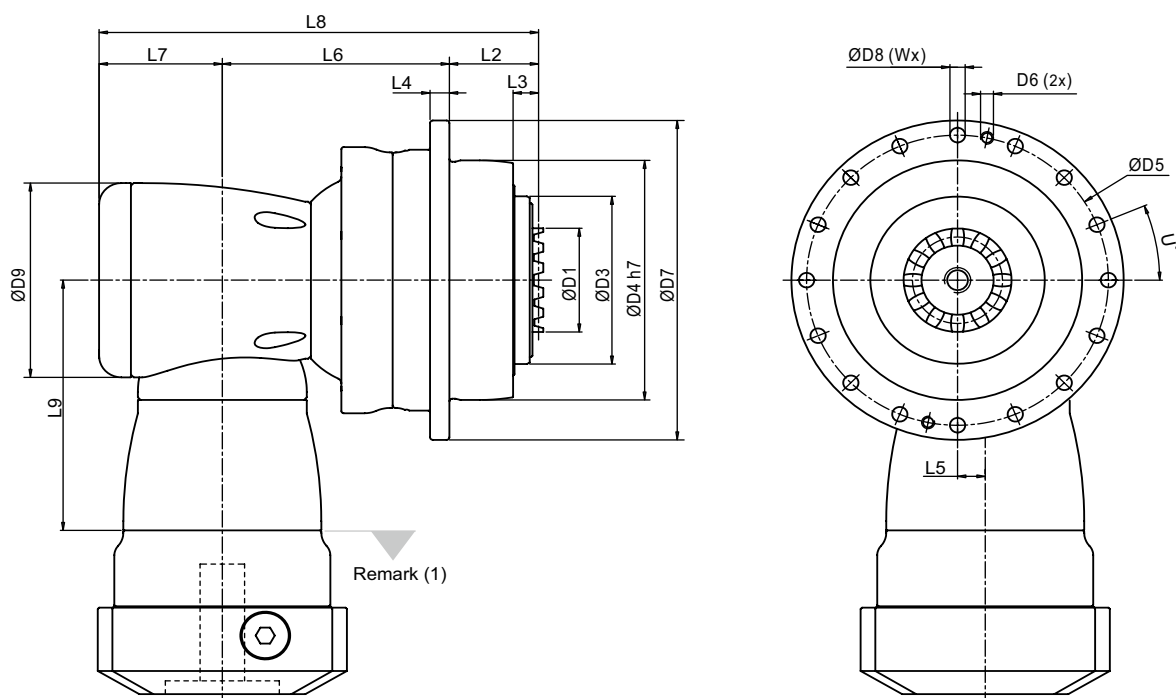

尺寸	APCK 110	APCK 140	APCK 200	APCK 255	APCK 285	APCK 355
D1	46	60	80	90	120	120
D3	80	100	160	180	200	250
D4 h7	110	140	200	255	285	355
D5	135	168	233	280	310	385
D6	-	-	-	M12	M12	M16
D7	147	180	249.5	302	332	415
D8	5.5	6.6	9	13.5	13.5	17.5
D9	116	163	210	210	255	300
L2	31.5	40.5	52.5	68.5	77.5	82.5
L3	9.5	10	11	16	19	22.5
L4	8	10	12	18	20	45
L5	17	25	31	31	36	43
L6	114	147.5	175	191.5	249.5	290
L7	68.3	89	115	115	131	165
L8	213.8	277	342.5	375	458	537.5
L9	129	173.5	228	228	265.5	294.5
U in Degree	22.5	15	15	11.25	11.25	15
W	16	24	24	32	32	24

(1) 尺寸与马达介面有关，详细资料请与 APEX 洽询。

尺寸 - APCK (三节) 减速机 (减速比 $i = 88 \sim 385$)

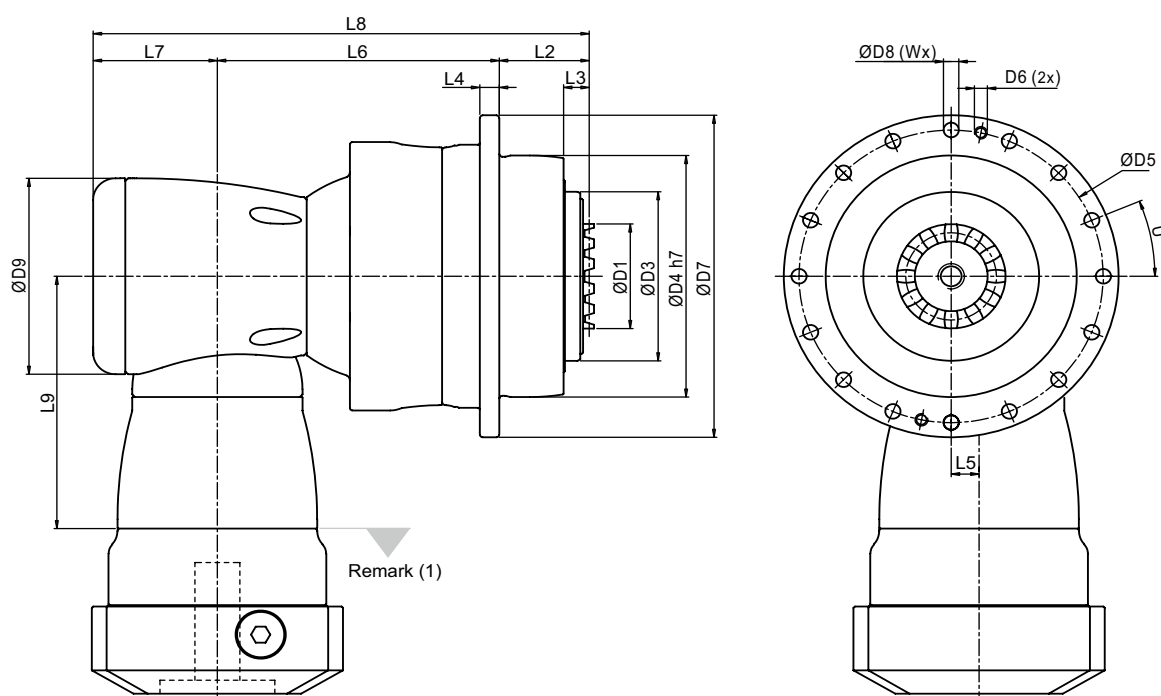

尺寸	APCK 110	APCK 140	APCK 200	APCK 255	APCK 285	APCK 355	APCK 450
D1	46	60	80	90	120	120	132
D3	80	100	160	180	200	250	315
D4 h7	110	140	200	255	285	355	450
D5	135	168	233	280	310	385	490
D6	-	-	-	M12	M12	M16	M16
D7	147	180	249.5	302	332	415	530
D8	5.5	6.6	9	13.5	13.5	17.5	22
D9	94	116	163	210	210	210	255
L2	31.5	40.5	52.5	68.5	77.5	82.5	87.5
L3	9.5	10	11	16	19	22.5	22.5
L4	8	10	12	18	20	45	60
L5	13	17	25	31	31	31	36
L6	132	164	216.5	254.5	300	332	447.5
L7	53	68.3	89	115	115	115	131
L8	216.5	272.8	358	438	492.5	529.5	666
L9	114.5	129	173.5	228	228	228	265.5
U in Degree	22.5	15	15	11.25	11.25	15	15
W	16	24	24	32	32	24	24

(1) 尺寸与马达介面有关，详细资料请与 APEX 洽询。

尺寸 - APCK (四节) 减速机 (减速比 $i = 440 \sim 5,500$)

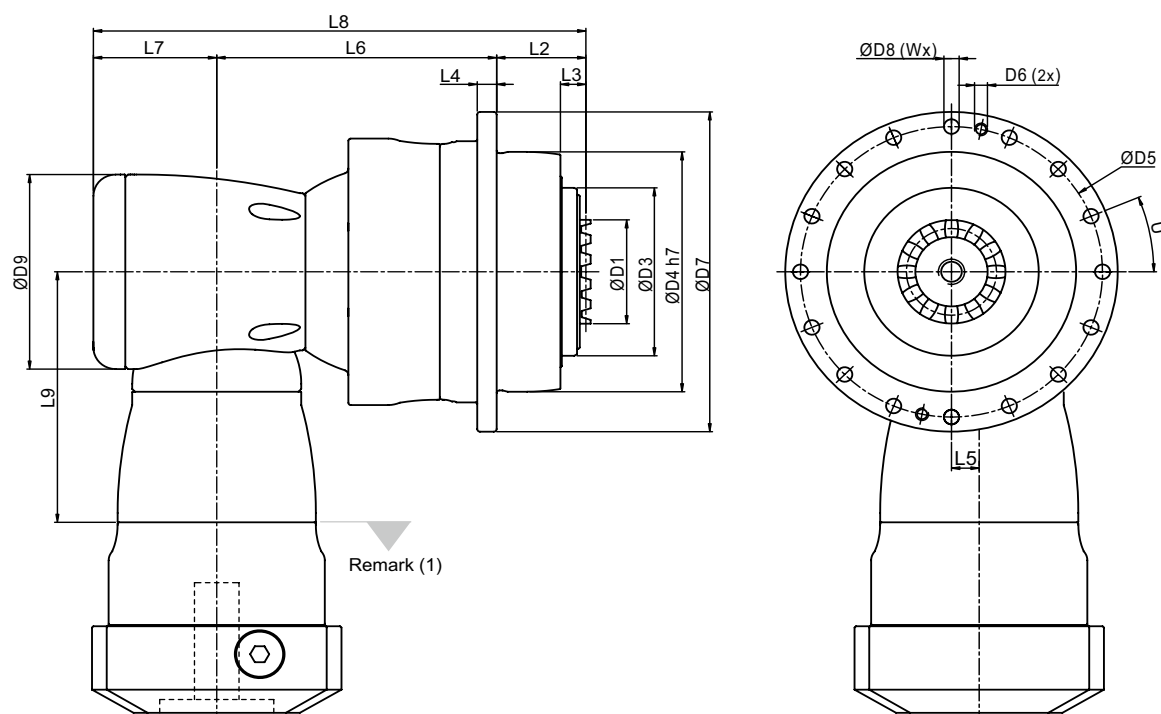

尺寸	APCK 110	APCK140	APCK 200	APCK 255	APCK 285	APCK 355	APCK 450
D1	46	60	80	90	120	120	132
D3	80	100	160	180	200	250	315
D4 h7	110	140	200	255	285	355	450
D5	135	168	233	280	310	385	490
D6	-	-	-	M12	M12	M16	M16
D7	147	180	249.5	302	332	415	530
D8	5.5	6.6	9	13.5	13.5	17.5	22
D9	94	116	163	210	210	210	255
L2	31.5	40.5	52.5	68.5	77.5	82.5	87.5
L3	9.5	10	11	16	19	22.5	22.5
L4	8	10	12	18	20	45	60
L5	13	17	25	31	31	31	36
L6	132	164	216.5	254.5	300	332	447.5
L7	53	68.3	89	115	115	115	131
L8	216.5	272.8	358	438	492.5	529.5	666
L9	114.5	129	173.5	228	228	228	265.5
U in Degree	22.5	15	15	11.25	11.25	15	15
W	16	24	24	32	32	24	24

(1) 尺寸与马达介面有关，详细资料请与 APEX 洽询。

性能 - APK / APCK (双节) 减速机 (减速比 $i = 5.5 \sim 11$)

型 号		节 数	减速比 ⁽¹⁾	APK 110 APCK 110	APK 140 APCK 140	APK 200 APCK 200	APK 255 APCK 255	APK 285 APCK 285
额定输出力矩 T_{2N}	Nm	2	5.5	370	645	1,435	2,180	4,080
			11	375	650	1,440	2,195	4,100
急停力矩 T_{2NOT}	Nm	2	5.5~11	2倍额定输出力矩				
最大加速力矩 T_{2B}	Nm	2	5.5~11	1.5倍额定输出力矩				
空载力矩 ⁽²⁾	Nm	2	5.5~11	5.8	12	25	48	95
背隙 ⁽³⁾	arcmin	2	5.5~11	≤ 1.3				
扭转刚性	Nm/arcmin	2	5.5~11	56	112	389	642	1,275
额定输入转速 n_{1N}	rpm	2	5.5~11	3,000	2,300	1,800	1,500	1,100
最大输入转速 n_{1B}	rpm	2	5.5~11	5,500	4,500	3,500	3,000	2,200
容许轴向力 F_{2a} ⁽⁴⁾	N	2	5.5~11	4,070	8,530	17,000	26,900	39,200
容许侧倾力矩 M_{2k} ⁽⁴⁾	Nm	2	5.5~11	480	1,310	3,530	5,920	9,230
使用寿命 ⁽⁵⁾	hr	2	5.5~11	20,000				
使用温度	°C	2	5.5~11	-10° C ~ 90° C				
防护等级		2	5.5~11	IP65				
润滑		2	5.5~11	合成润滑油脂				
安装方向		2	5.5~11	任意方向				
噪音值 ⁽²⁾	dB(A)	2	5.5~11	≤ 68	≤ 70	≤ 70	≤ 72	≤ 74
效率 η	%	2	5.5~11	$\geq 95\%$				

(1) 减速比 ($i = N_{in} / N_{out}$)。

(2) 以减速机减速比 11 (双节) 转速为 3000 rpm 且无负载状态下测得数据。

(3) 背隙是在受力 2% 的额定输出力矩 T_{2N} 下测得。

(4) 输出转速 100 rpm 时, 作用于法兰 / 曲齿连结位置。计算公式请参考 AP 系列页面(3)。

(5) 不建议连续运转。

惯量 - APK / APCK (双节) 减速机 (减速比 $i = 5.5 \sim 11$)

型 号		APK/APCK 110	APK/APCK 140	APK/APCK 200	APK/APCK 255	APK/APCK 285
$\varnothing^{(A)}$	节	2	2	2	2	2
19	kg.cm ²	1.71	-	-	-	-
24		5.05	6.92	-	-	-
28		6.55	6.98	-	-	-
32		9.47	10.18	-	-	-
35		14.91	15.21	15.21	-	-
38		20.69	20.7	20.7	-	-
42		-	22.83	22.83	23.59	-
48		-	58.45	58.45	59.3	61.61
55		-	-	-	86.95	89.67
60		-	-	-	-	112.49

(A) \varnothing = 减速机输入端孔径。

尺寸 - APK (双节) 减速机 (减速比 $i = 5.5 \sim 11$)

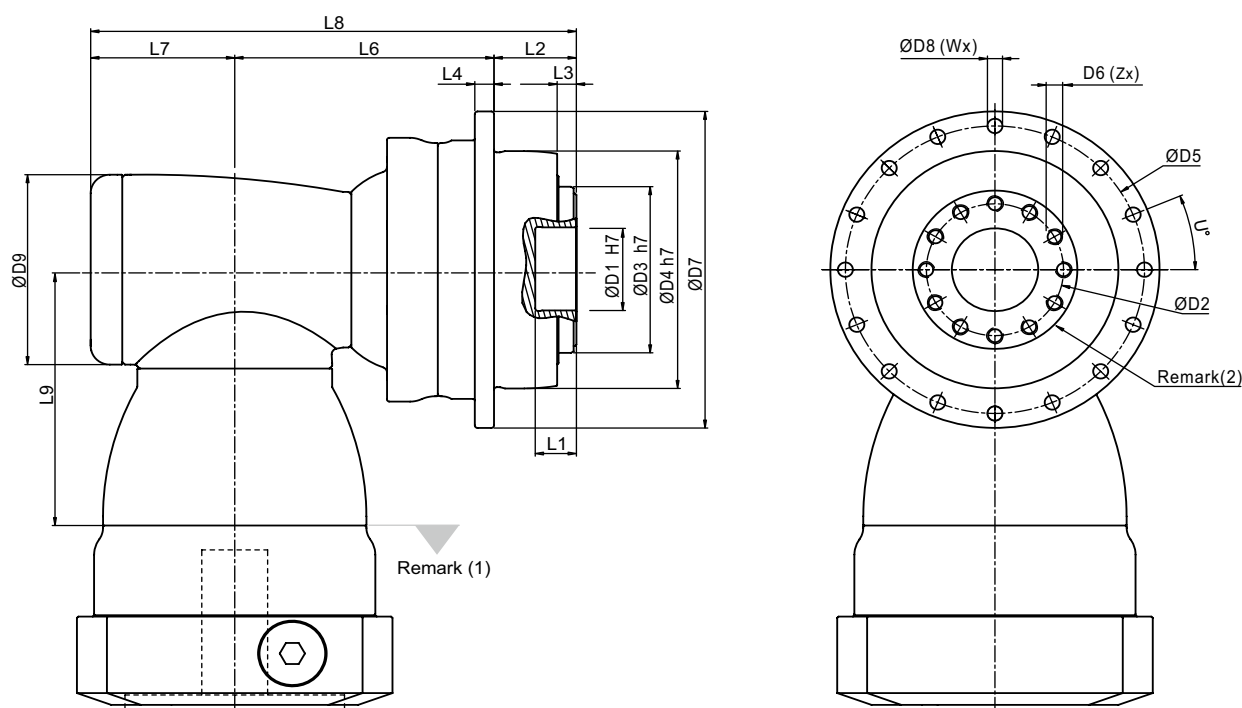

尺寸	APK 110	APK 140	APK 200	APK 255	APK 285
D1 H7	40	50	80	100	100
D2	63	80	125	140	160
D3 h7	80	100	160	180	200
D4 h7	110	140	200	255	285
D5	135	168	233	280	310
D6 x Pitch x Deep	M8x1.25Px12	M8x1.25Px15	M10x1.5Px20	M16x2Px25	M24x3Px37
D7	147	180	249.5	302	332
D8	5.5	6.6	9	13.5	13.5
D9	116	156	156	195	240
L1	15	15	16	16	16
L2	29	38	50	66	75
L3	7	7.5	8.5	13.5	16.5
L4	8	10	12	18	20
L6	124.5	175.5	185	199	265.5
L7	76	97.5	97.5	105.5	141
L8	229.5	311	332.5	370.5	481.5
L9	147.5	196.5	196.5	229	260
X in Degree	30	22.5	22.5	24	26
Y in Degree	30	22.5	22.5	24	26
Z	12	16	16	12	12
U in Degree	22.5	15	15	11.25	11.25
W	16	24	24	32	32

(1) 尺寸与马达介面有关，详细资料请与 APEX 洽询。

(2) 法兰介面请参考 AP 系列页面 (5)。

尺寸 - APCK (双节) 减速机 (减速比 $i = 5.5 \sim 11$)

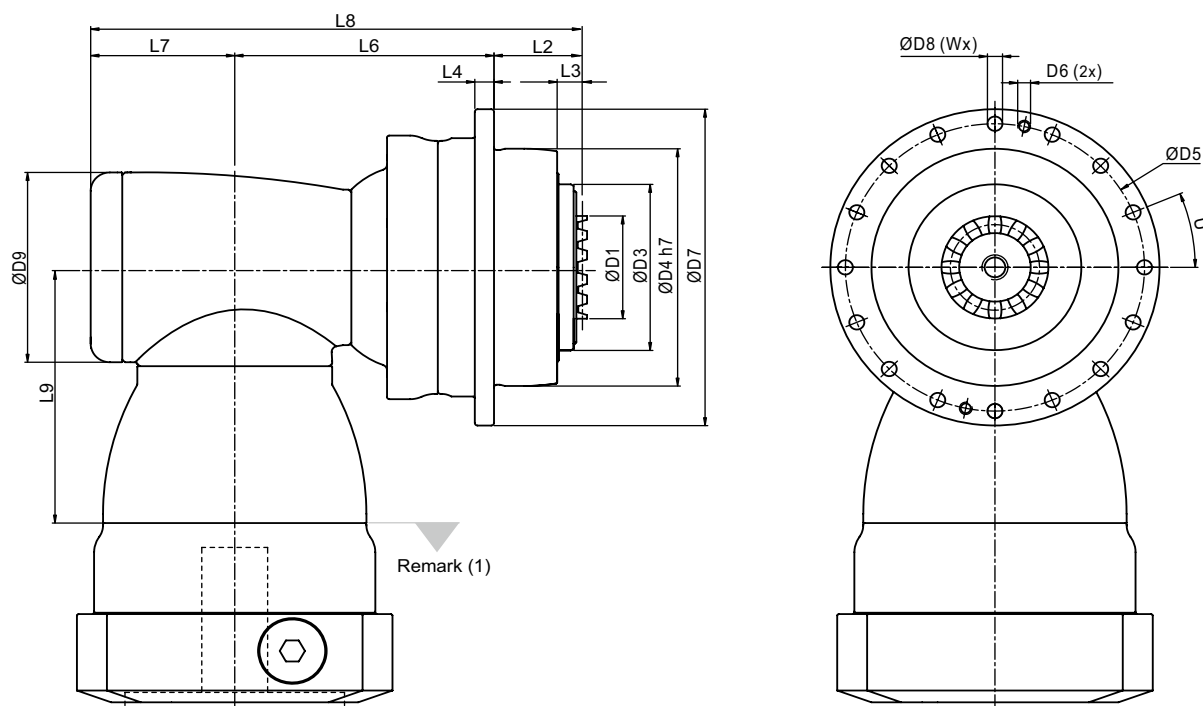

尺寸	APCK 110	APCK 140	APCK 200	APCK 255	APCK 285
D1	46	60	80	90	120
D3	80	100	160	180	200
D4 h7	110	140	200	255	285
D5	135	168	233	280	310
D6	-	-	-	M12	M12
D7	147	180	249.5	302	332
D8	5.5	6.6	9	13.5	13.5
D9	116	156	156	195	240
L2	31.5	40.5	52.5	68.5	77.5
L3	9.5	10	11	16	19
L4	8	10	12	18	20
L6	124.5	175.5	185	199	265.5
L7	76	97.5	97.5	105.5	141
L8	232	313.5	335	373	484
L9	147.5	196.5	196.5	229	260
U in Degree	22.5	15	15	11.25	11.25
W	16	24	24	32	32

(1) 尺寸与马达介面有关，详细资料请与 APEX 洽询。

曲齿介面齿轮

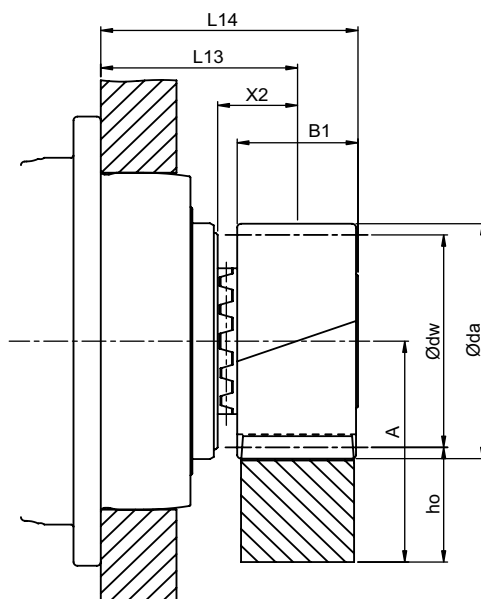

精度等级 DIN4/ 合金钢

齿厚公差 e24

左旋斜齿

左旋角 $\beta = 19^\circ 31' 42''$ (19.5283°)

压力角 $\alpha = 20^\circ$

渗碳淬火及齿面研磨

$$A = h_o + \frac{\varnothing dw}{2}$$

减速机型号	模数	Z ⁽¹⁾	X ⁽²⁾	da ⁽³⁾	d ⁽⁴⁾	dw ⁽⁵⁾	B1	X2	L13	L14	L ⁽⁶⁾	订购代码
APC/APCK 110	3	20	0.3897	72	63.662	66	31	20.5	49.5	65	200	A03L20
APC/APCK 140	4	19	0.4102	91.92	80.639	83.92	41	25.5	63.5	84	253.335	A04L19
APC/APCK 200	5	19	0.4002	114.8	100.798	104.8	51	30.5	80.5	106	316.666	A05L19
APC/APCK 255	6	19	0.4035	137.8	120.958	125.8	61	35.5	101.5	132	380	A06L19
APC/APCK 285	8	19	0.4108	183.85	161.277	167.85	81	45.5	120.5	161	506.667	A08L19
APC/APCK 355	8	19	0.4108	183.85	161.277	167.85	81	45.5	125.5	166	506.667	A08L19
APC/APCK 450	10	18	0.4257	219.5	190.986	199.5	101	55.5	140.5	191	600	A10L18

(1) 齿数 (2) 修正系数 (3) 齿顶圆直径 (4) 节圆直径 (5) 工作节圆直径 (6) 节圆长度 $L = \pi \times d$

- 齿轮材质渗碳淬火，表面硬度达 60 HRC
- 齿轮经研磨与修整，有效降低噪音与提高耐磨性

■ 表一 齿轮与齿条的容许最大驱动力

减速机型号	单位	Mn	Z ⁽¹⁾	dw ⁽²⁾	F _{2T} ⁽³⁾	T _{2B} ⁽⁴⁾	M
		【mm】		【mm】	【N】	【Nm】	【kg】
APC/APCK 110		3	20	66	18,535	590	0.92
APC/APCK 140		4	19	83.92	31,003	1,250	1.98
APC/APCK 200		5	19	104.8	48,612	2,450	3.81
APC/APCK 255		6	19	125.8	63,907	3,865	6.61
APC/APCK 285		8	19	167.85	131,265	10,585	15.49
APC/APCK 355 ⁽⁵⁾		8	19	167.85	131,761	10,625	15.49
APC/APCK 450 ⁽⁵⁾		10	18	199.5	204,308	19,510	28.13

(1) 齿数 (2) 节圆直径 (3) 最大驱动力 (4) 最大驱动力矩 (5) 该值以速度 1.5m/s 为基础计算

- 表一是齿条连接齿轮与齿条的容许最大驱动力，该值的计算基础是以速度 3m/s，且提供良好的润滑（使用自动润滑系统或每天手动涂抹润滑脂），齿根强度系数 $SF \geq 1.4$ ，齿面强度系数 $SH \geq 1$ ，安全系数 $SB = 1$ ，且要求使用寿命 20,000 小时。符合最佳条件下的最大值，在任何情况下的应用与配置都需经过校核。各产品在不同中心距偏差所产生的齿侧间隙变化资料，请访问我们的网站。<http://www.apexdyna.com/>

斜齿齿条 Quality 5

精度等级 Quality5/ 合金钢

齿厚公差 -15 ~ 0 μ m 右旋斜齿

右旋角 $\beta = 19^{\circ}31'42''$ (19.5283 $^{\circ}$) 压力角 $\alpha = 20^{\circ}$

齿面高周波硬化处理及研磨

四面研磨

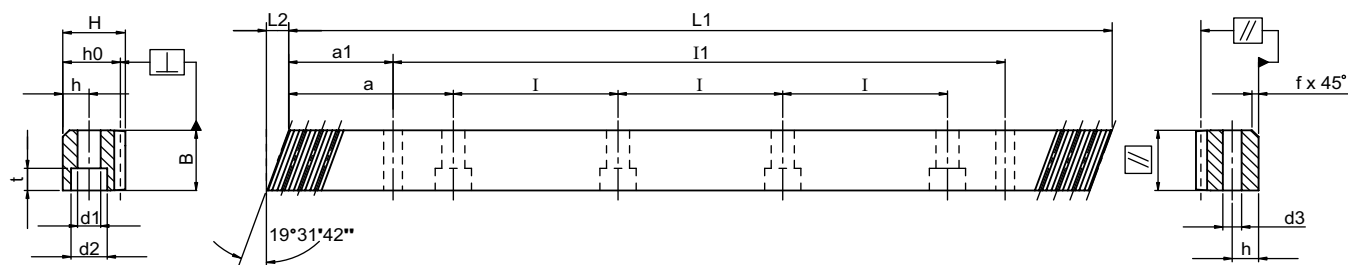

模数	$P_t^{(1)}$	L1	L2	齿数	B	H	h ₀	f	a	I	沉头孔数	h	d1	d2	t	a1	I1	d3	fp ⁽²⁾	Fp ⁽³⁾	订购代码
3	10.00002	500	10.3	50	29	29	26	2	62.5	125	4	9	10	15	9	35	430	7.7	0.006	0.023	0305R050M10
3	10.00002	1,000	10.3	100	29	29	26	2	62.5	125	8	9	10	15	9	35	930	7.7	0.006	0.026	0305R100M10
3	10.00002	1,250	10.3	125	29	29	26	2	62.5	125	10	9	10	15	9	35	1,180	7.7	0.006	0.026	0305R125M10
3	10.00002	1,500	10.3	150	29	29	26	2	62.5	125	12	9	10	15	9	35	1,430	7.7	0.006	0.026	0305R150M10
3	10.00002	1,750	10.3	175	29	29	26	2	62.5	125	14	9	10	15	9	35	1,680	7.7	0.006	0.026	0305R175M10
3	10.00002	2,000	10.3	200	29	29	26	2	62.5	125	16	9	10	15	9	35	1,930	7.7	0.007	0.03	0305R200M10
4	13.33335	506.67	13.8	38	39	39	35	3	62.5	125	4	12	10	15	9	33.3	433	7.7	0.007	0.025	0405R050C10
4	13.33335	1,000	13.8	75	39	39	35	3	62.5	125	8	12	10	15	9	33.3	933.4	7.7	0.007	0.028	0405R100C10
4	13.33335	1,000	13.8	75	39	39	35	3	62.5	125	8	12	14	20	13	33.3	933.4	11.7	0.007	0.028	0405R100CS0
4	13.33335	1,253.34	13.8	94	39	39	35	3	62.5	125	10	12	10	15	9	33.3	1186.7	7.7	0.007	0.028	0405R125C10
4	13.33335	1,506.67	13.8	113	39	39	35	3	62.5	125	12	12	10	15	9	33.3	1,433.4	7.7	0.007	0.028	0405R150C10
4	13.33335	1,506.67	13.8	113	39	39	35	3	62.5	125	12	12	14	20	13	33.3	1,433.4	11.7	0.007	0.028	0405R150CS0
4	13.33335	1,760	13.8	132	39	39	35	3	62.5	125	14	12	10	15	9	33.3	1,693.4	7.7	0.007	0.028	0405R175C10
4	13.33335	2,000	13.8	150	39	39	35	3	62.5	125	16	12	10	15	9	33.3	1,933.4	7.7	0.008	0.032	0405R200C10
4	13.33335	2,000	13.8	150	39	39	35	3	62.5	125	16	12	14	20	13	33.3	1,933.4	11.7	0.008	0.032	0405R200CS0
5	16.66669	1,000	17.4	60	49	49	34	3	62.5	125	8	12	14	20	13	37.5	925	11.7	0.007	0.028	0505R100C10
6	20.00003	1,000	20.9	50	59	59	43	3	62.5	125	8	16	18	26	17	37.5	925	15.7	0.007	0.028	0605R100C10
8	26.66671	960	28	36	79	79	71	3	60	120	8	25	22	33	21	120	720	19.7	0.008	0.031	0805R100C10
10	33.33339	1,000	35.1	30	99	99	89	3	62.5	125	8	32	33	48	32	125	750	19.7	0.008	0.031	1005R100C10

(1) 端面齿距 = 模数 $\times \pi / \cos \beta$ (2) fp = 单节距误差 (3) Fp = 总节距误差

■ 其他齿条型号, 请参考 APEX 高精密度齿条与齿轮型录

减速机的选用

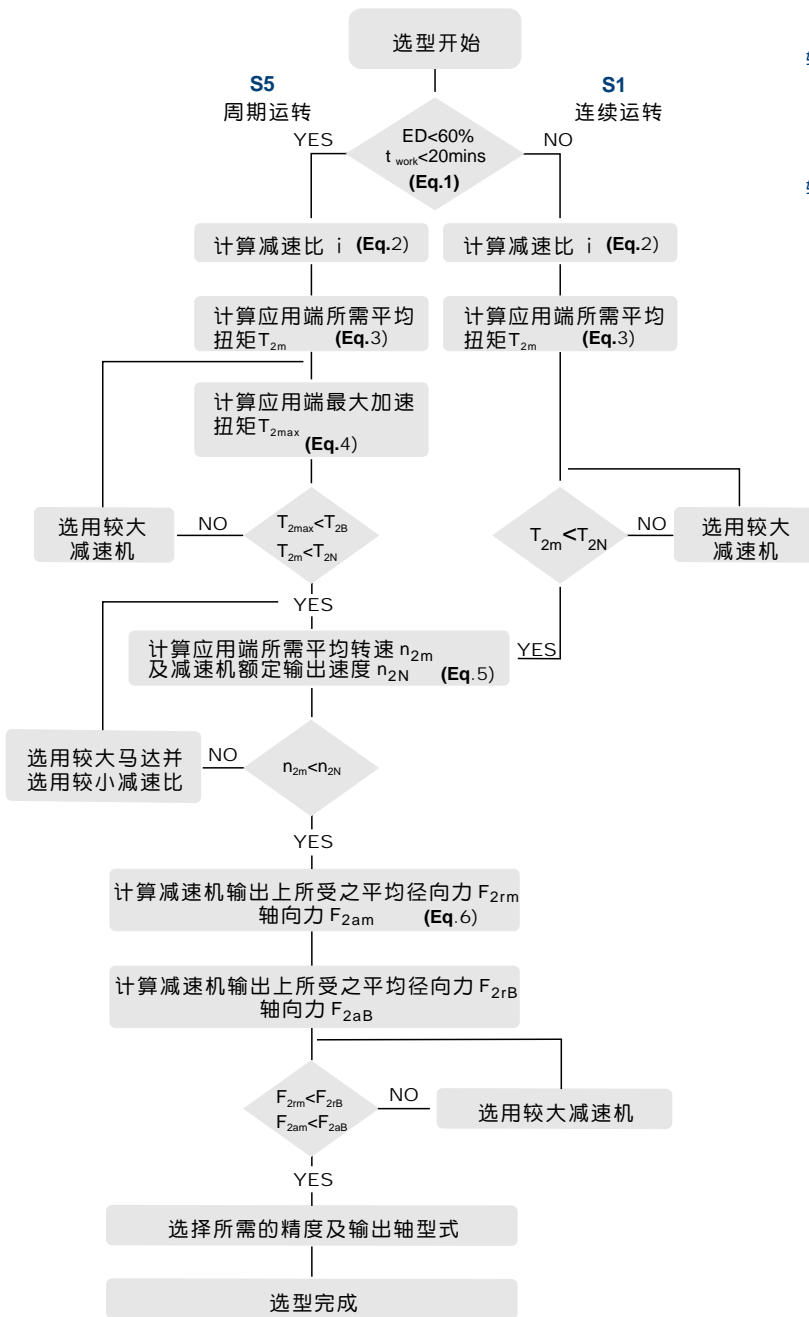

S5 周期运转之建议事项
一般的应用惯量须符合以下公式

$$\frac{J_L}{i^2} \leq 4 \times J_m$$

最适当的应用惯量须符合以下公式

$$\frac{J_L}{i^2} \cong J_m$$

J_L 负载惯量

J_m 马达惯量

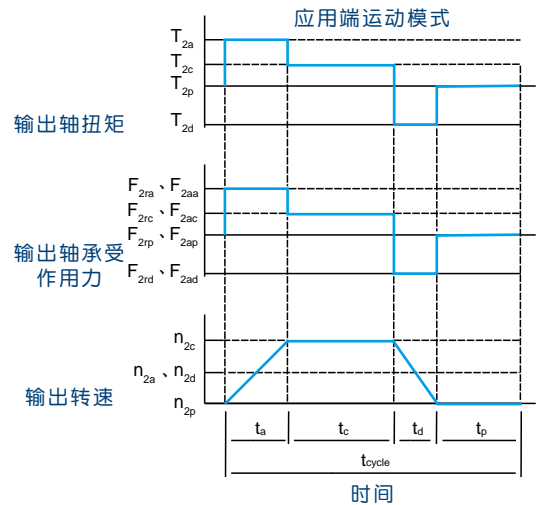

$$1. ED = \frac{t_a + t_c + t_d}{t_{cycle}} \times 100\%, t_{work} = t_a + t_c + t_d$$

下标说明: a. 加速 c. 等速
d. 减速 p. 停止 (Eq.1)

$$2. i \cong \frac{n_m}{n_{work}}$$

n_m 马达输出速度
 n_{work} 实际应用速度 (Eq.2)

$$3. T_{2m} = \sqrt[3]{\frac{n_{2a} \times t_a \times T_{2a}^3 + n_{2c} \times t_c \times T_{2c}^3 + n_{2d} \times t_d \times T_{2d}^3}{n_{2a} \times t_a + n_{2c} \times t_c + n_{2d} \times t_d}}$$

(Eq.3)

$$4. T_{2max} = T_{mB} \times i \times K_s \times \eta$$

K _s 负载系数	
K _s	周期次数 / 小时
1.0	0 ~ 1,000
1.1	1,000 ~ 1,500
1.3	1,500 ~ 2,000
1.6	2,000 ~ 3,000
1.8	3,000 ~ 5,000

T_{mB} 马达最大输出扭矩

η 减速机运转效率 (Eq.4)

$$5. n_{2a} = n_{2d} = \frac{1}{2} \times n_{2c}$$

$$n_{2m} = \frac{n_{2a} \times t_a + n_{2c} \times t_c + n_{2d} \times t_d}{t_a + t_c + t_d}$$

$$n_{2N} = \frac{n_{1N}}{i}$$

(Eq.5)

$$6. F_{2rm} = \sqrt[3]{\frac{n_{2a} \times t_a \times F_{2ra}^3 + n_{2c} \times t_c \times F_{2rc}^3 + n_{2d} \times t_d \times F_{2rd}^3}{n_{2a} \times t_a + n_{2c} \times t_c + n_{2d} \times t_d}}$$

$$F_{2am} = \sqrt[3]{\frac{n_{2a} \times t_a \times F_{2aa}^3 + n_{2c} \times t_c \times F_{2ac}^3 + n_{2d} \times t_d \times F_{2ad}^3}{n_{2a} \times t_a + n_{2c} \times t_c + n_{2d} \times t_d}}$$

(Eq.6)

词汇表

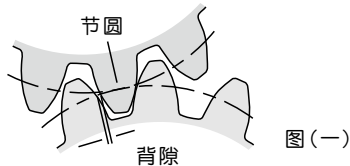
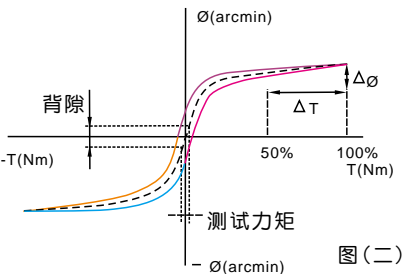
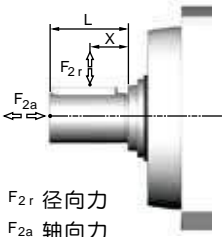
急停力矩 T_{2NOT}	Nm	减速机输出端可承受的最大力矩。在使用寿命内，此类偶发状况不得超过1,000次。
最大加速力矩 T_{2B}	Nm	在周期运转(S5)条件下，减速机输出端在短时间内可承受的最大力矩。
空载力矩	Nm	减速机输出端在无负载下，克服减速机内部摩擦力的力矩。
额定输入转速 n_{1N}	rpm	减速机输入端在连续运转(S1)下，可容许的输入转速，此数值在环境温度25°C下测得，实际运作时，箱体温度不得超过90°。
最大输入转速 n_{1B}	rpm	减速机输入端在周期运转(S5)下，可容许的输入转速，此数值在环境温度25°C下测得，实际运作时，箱体温度不得超过90°。
背隙	arcmin	<p>背隙为减速机运作时，齿轮运转改变方向，两齿之间最大的间隙，如图(一)所示，弧分是量测背隙角度的单位，1弧分等于1/60度，标示为1'。</p> 
扭转刚性	Nm/arcmin	<p>扭转刚性为力矩与扭转角度的比值($\Delta T / \Delta \varnothing$)，表示输出轴转动1弧分，需要多少的扭力，扭转刚性可由迟滞曲线计算出来。</p> <p>迟滞曲线： 量测迟滞曲线时，先固定减速机输入轴，然后双向增加力矩到最大加速力矩T_{2B}，并逐渐卸载力矩，依照检测中力矩与扭转角度的变化可以得到一条闭合的曲线，如图(二)：迟滞曲线所示，从图中即可得知减速机的扭转刚性。</p> 
径向力与轴向力	N	<p>减速机输出轴所能承受之最大径向力及轴向力，视内部支撑轴承之设计。</p> <p>更多的相关资料，请参考APEX网页。</p> 
效率 η	%	减速机内部齿轮的啮合效率(不含摩擦)。
使用温度	°C	此温度为减速机箱体温度(非环境温度)。
防护等级		国际防护标准(International Protection)以IP编码表示其防护能力，例：IP65;第一个数字表示防尘等级，第二个数字表示防水等级。
润滑		APEX使用合成润滑油，如有食品等级或低温的需求，请与APEX联络。
噪音值	dB(A)	噪音值会随着减速机的比数与转速而异。
转动惯量	kg.cm ²	转动惯量为物体保持本身转动状态的特性参数。
启动力矩	Nm	由输入端驱动减速机至开始转动的最小力矩，小尺寸与减速比比数较高的减速机启动力矩较低。
反驱动力矩	Nm	由输出端驱动减速机至开始转动的最小力矩，大尺寸与减速比比数较高的减速机需要较高的反驱动力矩。

*此数据是在环境温度25°与减速机输入转速3,000 rpm下测得。如果该减速机的额定输入转速 n_{1N} 超过3,000 rpm，则以该减速机的额定输入转速进行量测。



APEX DYNAMICS, INC.

杭州摩森机电科技有限公司

杭州市滨江区聚园路8号创海基地D503室

电话: 0571-86622450

传真: 0571-86625450

<http://www.apexms.cn>

E-mail: info@hzmosen.com

服务热线: 0571-86622450



公司网址